

LM10 incremental linear magnetic encoder system

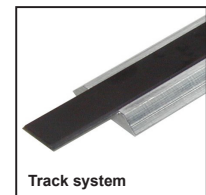
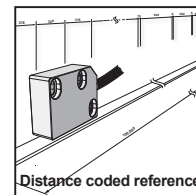
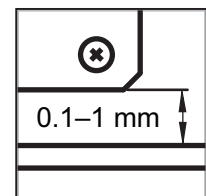

The LM10 is a contactless high-speed linear magnetic encoder designed for use in harsh environments.

The LM10 features a compact sealed readhead that rides at up to 1.0 mm from the self-adhesive magnetic strip scale, which brings up to 100 m travel.

Simple to install, the LM10 features an integral set-up LED, wide installation tolerances and an applicator tool for the adhesive-backed magnetic scale. A bidirectional reference is provided that can be actuated either by a preset mark integrated within the scale or by adding a reference sticker on top of the scale with the help of a self-aligning installation tool.

The encoders come in digital or analogue output variants and offer a range of customer selectable resolutions from 0.244 μm to 250 μm . The LM10 is capable of velocities up

to 80 m/s; even at 1 μm resolution it is capable of more than 7 m/s.

Engineered for extreme service, the solid-state LM10 linear encoders operate from $-10\text{ }^{\circ}\text{C}$ to $+80\text{ }^{\circ}\text{C}$, have water-proof sealing to IP68 and are highly resistant to shock, vibration and pressure. The robust magnetic scale is also resistant to a range of chemicals commonly found in industry.

The non-contact, frictionless design eliminates wear while reducing hysteresis.

The LM10 encoders bring reliable solutions to tough, hard-working applications including woodworking, stone-cutting, sawing, metalworking, textiles, printing, packaging, plastics processing, automation and assembly systems, laser/flame/water-jet cutting, electronic assembly equipment etc.

- Customer selectable resolutions
- Stick-on reference mark
- Distance coded reference and periodic reference mark option
- High speed operation
- Excellent dirt immunity to IP68
- Integral set-up LED
- Axis lengths of up to 100 m
- High reliability from proven non-contact sensing technology
- Industry standard incremental digital and analogue output options
- CE compliant, including RoHS - see Declaration of conformity

Storage and handling

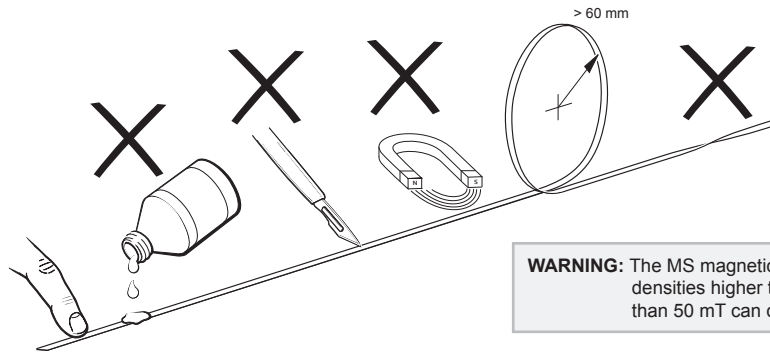

WARNING: The MS magnetic scale should not be exposed to magnetic field densities higher than 50 mT on its surface. Magnetic fields higher than 50 mT can damage the scale.

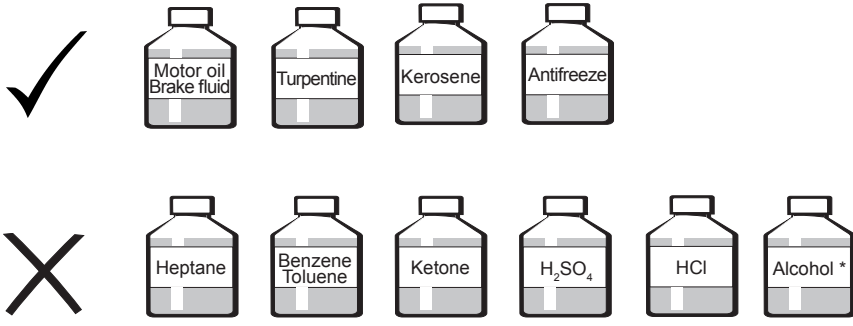

* Use of alcohol for cleaning is considered safe, however, it is not allowed to immerse the scale in alcohol.

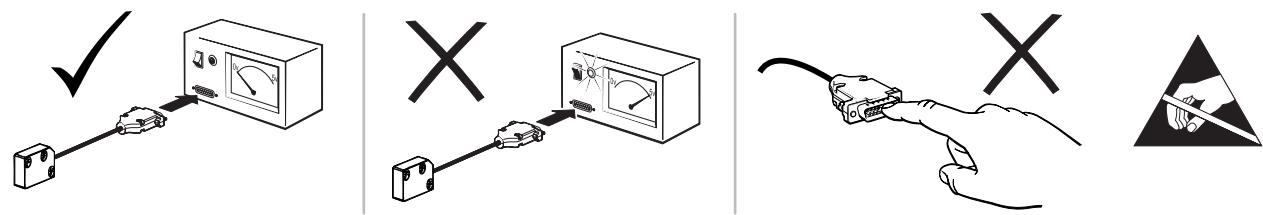

Electrical connections

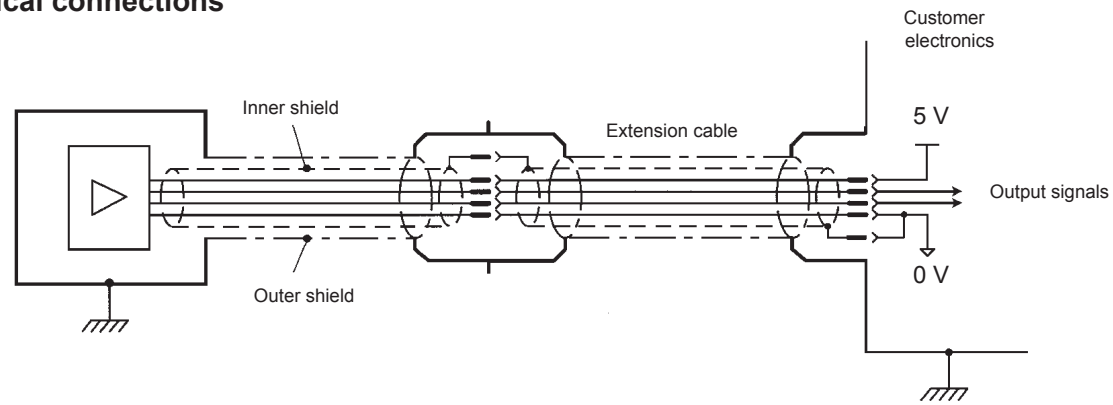

Dimensions

Dimensions and tolerances in mm.

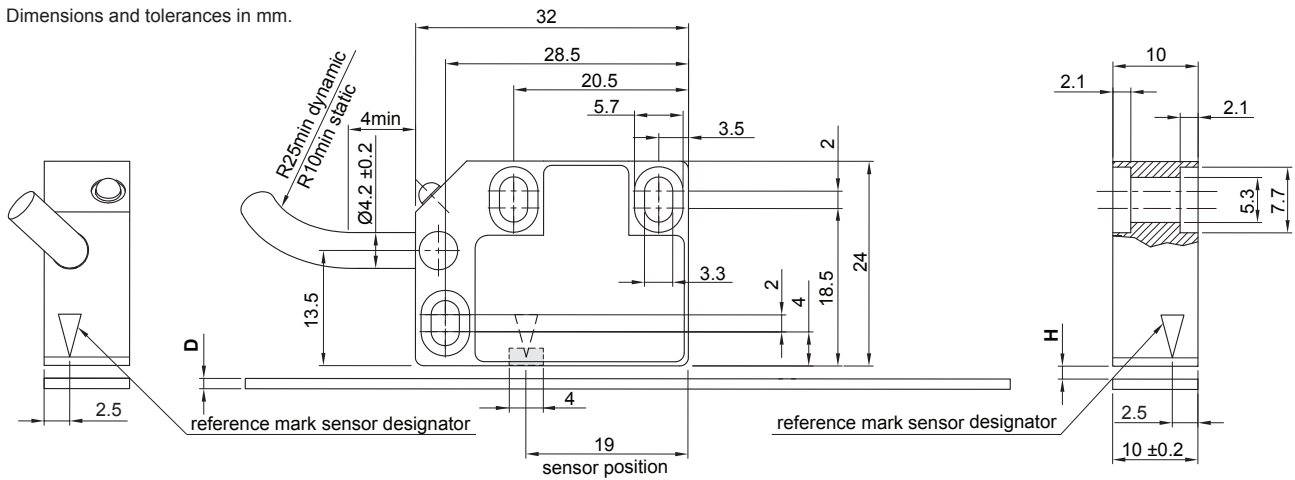

NOTE: Ensure recommended M3 readhead fixing screws are tightened to 0.5 Nm to 0.7 Nm.

	Magnetic scale thickness (D)		Ride height (H)	
	With back adhesion*	Without back adhesion*	Maximum range	Recommended range**
No cover foil, cut or magnetised reference mark	1.5 ± 0.15	1.3 ± 0.15	0.1–1.5	0.1–1.0 For AS output: 0.1–0.5
No cover foil, stick-on reference mark	1.5 ± 0.15	1.3 ± 0.15	0.5–1.5	0.5–1.0
With cover foil, cut or magnetised reference mark	1.6 ± 0.15	1.4 ± 0.15	0.1–1.3	0.1–0.9 For AS output: 0.1–0.4
With cover foil, stick-on reference mark	1.6 ± 0.15	1.4 ± 0.15	0.5–1.3	0.5–0.9

* See MS10 part numbering on page 12 for more information on the options available.

** For greater ride heights please see [LM15 linear encoder system \(LM15D01\)](#).

Installation tolerances

Ride height

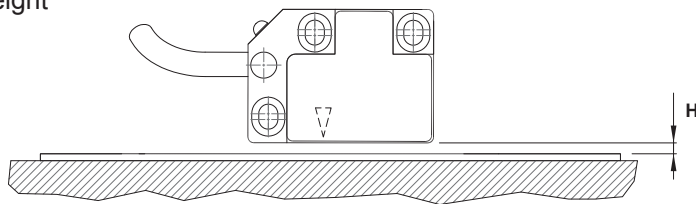

Pitch

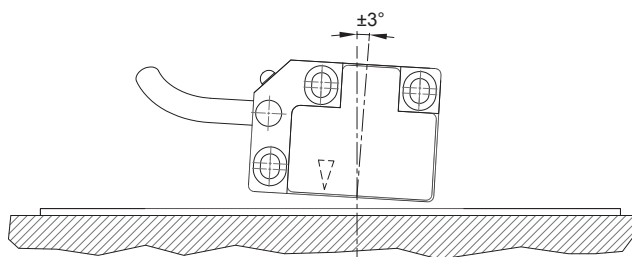

Yaw

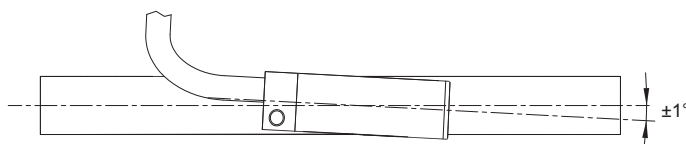

Lateral offset

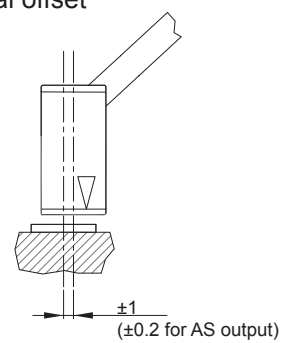

Roll

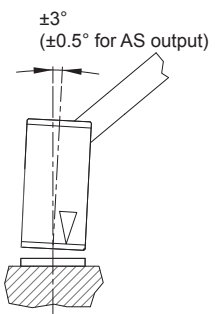

Technical specifications

System data											
Maximum length for MS scale	100 m (up to 180 m per request)										
Pole length	2 mm										
Sinusoidal period length (for analogue voltage output)	2 mm										
Available resolutions and maximum speed	For analogue voltage output: 80 m/s For digital output signals:										
Ordering code	Resolution (µm)	Counts / 2 mm	Maximum speed (m/s)								
			1.82	0.91	0.23	0.11	0.06	0.03	0.02	0.01	0.01
13B	≈ 0.244	8,192	1.82	0.91	0.23	0.11	0.06	0.03	0.02	0.01	0.01
12B	≈ 0.488	4,096	3.65	1.82	0.46	0.23	0.12	0.06	0.05	0.02	0.01
11B	≈ 0.976	2,048	7.30	3.65	0.91	0.46	0.24	0.12	0.10	0.05	0.02
001	1	2,000	7.47	3.73	0.93	0.47	0.24	0.12	0.10	0.05	0.02
1D6	1.25	1,600	9.33	4.67	1.17	0.58	0.30	0.16	0.12	0.06	0.03
10B	≈ 1.953	1,024	14.58	7.30	1.82	0.91	0.48	0.24	0.19	0.10	0.05
002	2	1,000	14.93	7.47	1.87	0.93	0.49	0.25	0.20	0.10	0.05
D80	2.5	800	18.67	9.33	2.34	1.17	0.61	0.31	0.25	0.12	0.06
09B	≈ 3.906	512	29.17	14.58	3.65	1.82	0.95	0.49	0.38	0.19	0.10
D50	4	500	29.87	14.93	3.73	1.87	0.97	0.50	0.39	0.20	0.10
005	5	400	37.33	18.67	4.67	2.34	1.22	0.62	0.49	0.25	0.12
D32	6.25	320	46.67	23.33	5.84	2.91	1.52	0.78	0.61	0.31	0.16
08B	≈ 7.812	256	58.34	29.17	7.30	3.65	1.90	0.97	0.77	0.39	0.19
010	10	200	74.67	37.33	9.33	4.67	2.43	1.24	0.98	0.50	0.25
D16	12.5	160	46.67	23.33	5.84	2.91	1.52	0.78	0.78	0.78	0.78
07B	15.625	128	80.00	58.34	14.58	7.30	3.81	1.94	1.53	0.77	0.39
020	20	100	74.67	37.33	9.33	4.67	2.43	1.24	0.98	0.50	0.25
D08	25	80	46.67	23.33	5.84	2.91	1.52	0.78	0.78	0.78	0.78
06B	31.25	64	80.00	80.00	29.17	14.58	7.62	3.89	3.07	1.55	0.78
050	50	40	46.67	23.33	5.84	2.91	1.52	0.78	0.78	0.78	0.78
05B	62.5	32	80.00	80.00	58.34	29.17	15.22	7.78	6.14	3.10	1.56
04B	125	16	NA	80.00	80.00	58.34	30.43	15.56	12.28	6.19	3.11
03B	250	8	NA	NA	80.00	80.00	60.86	31.11	24.56	12.39	6.23
Minimum edge separation (µs)			0.07	0.13	0.50	1	2	4	5	10	20
Maximum count frequency (MHz)			15	8	2	1	0.5	0.25	0.2	0.1	0.05
Ordering code			K	A	B	C	D	E	F	G	H
Accuracy grade for MS scales	±20 µm (available for lengths up to 50 m only) and ±40 µm										
Linear expansion coefficient for MS scale	~ 17 × 10 ⁻⁶ /K										
Repeatability	Better than unit of resolution for movement in the same direction										
Hysteresis	< 4 µm up to 0.5 mm ride height										
Mass	Readhead (1 m cable, no connector) 57 g, Cable (1 m) 34 g Magnetic scale (1 m) 60 g, Cover foil (1 m) 3.5 g										
Cable data											
Voltage drop over cable	~ 13 mV/m – without load ~ 54 mV/m – with 120 Ω load										
Cable	Ø4.2 ± 0.2 mm, PUR high flexible cable, drag-chain compatible, double-shielded 8-wire cable; white wire: 1x 26 AWG (19x 0.1 mm strands), other wires: 7x 30 AWG (7x 0.1 mm strands) Durability: 20 million cycles at 25 mm bend radius Special option 07: 12-wire cable, Ø4.5 ± 0.2 mm; 12x 28 AWG (7x 0.13 mm strands)										
Environmental											
Temperature	Operating –10 °C to +80 °C (cable under non-dynamic conditions: -20 °C to +85 °C) Storage –40 °C to +85 °C										
Environmental sealing	IP68 (according to IEC 60529)										
EMC Immunity	IEC 61000-6-2 (particularly: ESD: IEC 61000-4-2; EM fields: IEC 61000-4-3; Burst: IEC 61000-4-4; Surge: IEC 61000-4-5; Conducted disturbances: IEC 61000-4-6; Power frequency magnet fields: IEC 61000-4-8; Pulse magnetic fields: IEC 61000-4-9)										
EMC Emission	IEC 61000-6-4 (for industrial, scientific and medical equipment: IEC 55011)										
Vibrations (55 Hz to 2000 Hz)	300 m/s ² (IEC 60068-2-6)										
Shocks (11 ms)	300 m/s ² (IEC 60068-2-27)										

LM10AV and LM10AS* – Incremental analogue output signals (1 V_{pp})

2 channels V₁ and V₂ differential sinusoidals (90° phase shifted)

Power supply **	4.7 V to 7 V – voltage on readhead Reverse polarity protection	
Power consumption	< 50 mA	
Voltage drop over cable	~ 13 mV/m – without load ~ 54 mV/m – with 120 Ω load	
Output signals	V ₁ , V ₂ , V ₀	
Sine / cosine signals	Amplitude (with 120 Ω termination)	0.6 V _{pp} to 1.2 V _{pp}
	Phase shift	90° ± 0.5°
Reference signal	Amplitude (with 120 Ω termination)	0.8 V _{pp} to 1.2 V _{pp}
	Position	45°
	Width	22.5° for AV output 360° ± 180° for AS* output
Termination	Z ₀ = 120 Ω between associated outputs	
Cable length **	50 m max.	

Timing diagram

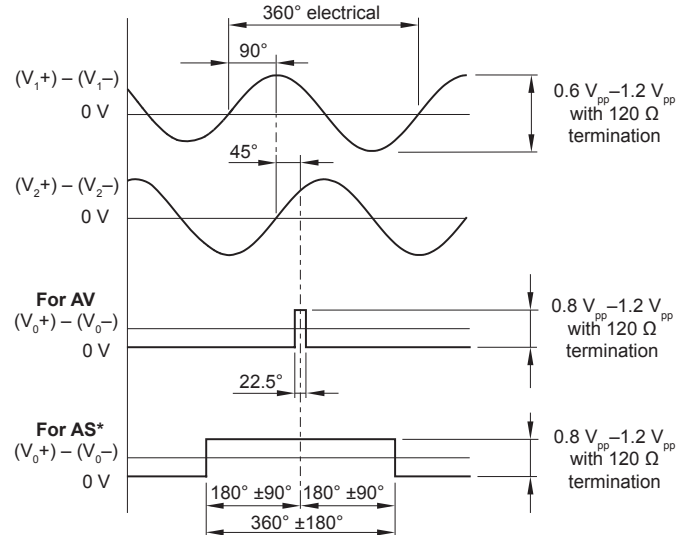

* AS output type is compatible with controllers (eg. Siemens, Fanuc) with 1 V_{pp} encoder inputs.

AS output type cannot be used with stick-on reference or cut reference mark.

AS output type has limitations in sensing distance (ride height), lateral offset and roll (see page 3).

** Please consider voltage drop over cable.

Recommended signal termination

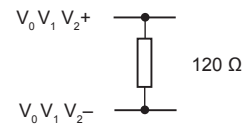

Connections

Function	Signal	Colour (option F)	15 pin D type plug (option L)	9 pin D type plug (option A)	9 pin D type plug (option P)
Power	5 V	Brown	4	5	5
	0 V	White	12	9	1
Analogue signals	V ₁	Green	9	4	2
	V ₁ [–]	Yellow	1	8	6
	V ₂	Blue	10	3	4
Reference signals	V ₂ [–]	Red	2	7	8
	V ₀	Pink	3	2	3
Shield	V ₀ [–]	Grey	11	6	7
	Inner	–	15	1	9
	Outer	–	Case	Case	Case

LM10IA – Incremental, push-pull; 24 V power supply

Power supply *	4.7 V to 30 V – voltage on readhead Without reverse polarity protection
Power consumption	< 35 mA
Voltage drop over cable	~ 13 mV/m – without load ~ 54 mV/m – with 120 Ω load
Response time **	< 100 ms < 10 μs (special option 02)
Output signals	3 square-wave signals A, B, Z and their inverted signals A–, B–, Z–
Reference signal	1 or more square-wave pulse Z and its inverted pulse Z–
Signal level	For 30 V: $U_H \geq 29.2 \text{ V}$ at $-I_H = 30 \text{ mA}$ $U_L \leq 0.5 \text{ V}$ at $I_L = 30 \text{ mA}$ For 5 V: $U_H \geq 4.2 \text{ V}$ at $-I_H = 20 \text{ mA}$ $U_L \leq 0.5 \text{ V}$ at $I_L = 20 \text{ mA}$
Permissible load	$I_L \leq 50 \text{ mA}$ max. load per output Outputs are protected against short circuit to 0 V and to +5 V
Alarm	High impedance on output lines A, B, A–, B– Special option 02: Alarm is not signalled by high impedance state ** Special option 07: Alarm signal is output parallel as line driver signal
Switching time (10 to 90 %)	For 24 V: $t_+ = t_- < 380 \text{ ns}$ (typ. 120 ns) For 5 V: $t_+ = t_- < 200 \text{ ns}$ (typ. 42 ns) Measured at $C_{LOAD} = 1000 \text{ pF}$
Cable length *	max. 100 m

* If power supply voltage is <10 V, please consider voltage drop over cable.

** See description on page 10.

Timing diagram

Complementary signals not shown

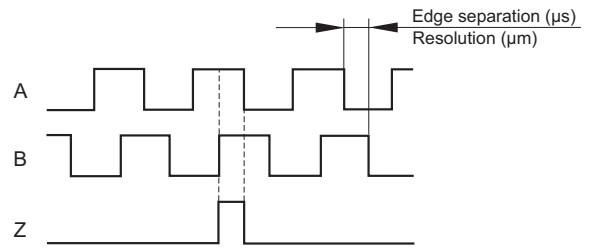

Recommended signal termination

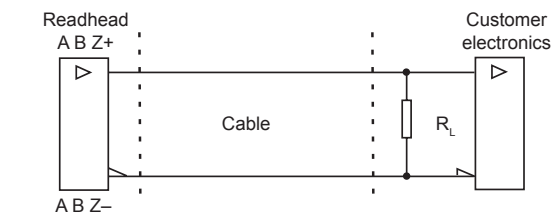

V_{supply}	R_L	I_{load}
5 V	250 Ω	20 mA
30 V	1 kΩ	30 mA

Connections

Function	Signal	Colour (option F)	15 pin D type plug (option D)	9 pin D type plug (option A)	15 pin HD type plug (option H)	7 pin DIN EN60130-9 plug (option U)
Power	5 V	Brown	7	5	7	5
	0 V	White	2	9	2	1
Incremental signals	A	Green	14	4	14	3
	A–	Yellow	6	8	6	–
	B	Blue	13	3	13	4
	B–	Red	5	7	5	–
Reference signals	Z	Pink	12	2	12	6
	Z–	Grey	4	6	4	–
Alarm	E	Violet	11	–	11	–
	E–	Black	3	–	3	–
Shield	Inner	–	15	1	15	–
	Outer	–	Case	Case	Case	Case

LM10IB – Digital output signals, Open Collector NPN

Square wave output

Power supply	5 V to 30 V Without reverse polarity protection
Power consumption	< 35 mA
Voltage drop over cable	~ 13 mV/m – without load ~ 54 mV/m – with 120 Ω load
Output signals	A, B, Z
Reference signal	1 or more square-wave pulses Z
Maximum load	10 mA
Cable length	See table below

Power supply voltage	Maximum cable length ** (m)			
	5 V	12 V	24 V	30 V
Edge separation (μs)				
0.07	0.2	0.3	1	1.5
0.12	3	2.5	1	1
0.5	10	7	4	3
1	10	10	9	6
2, 4, 5, 10, 20	10	10	10	10
R_L (Ω) *	500	1200	2400	3000

* Recommended values. For higher values of R_L shorter cables should be used.

** Encoder cable length and all other cable extensions should be taken into account.

Set-up LED is flashing red in case of poor signal strength.

Timing diagram

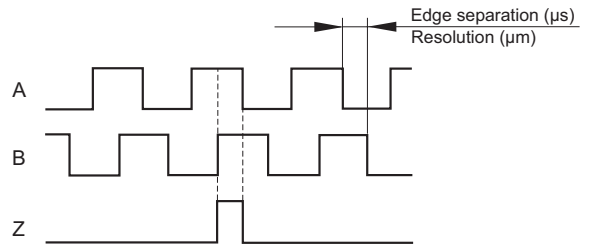

Recommended signal termination

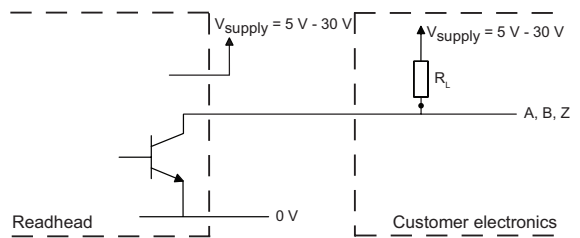

V _{supply}	R _{L min}
5	500
12	1,200
24	2,400
30	3,000

Connections

Function	Signal	Colour (option F)	9 pin D type plug (option A)	7 pin DIN EN60130-9 plug (option U)
Power	5 V	Brown	5	5
	0 V	White	9	1
Incremental signals	A	Green	4	3
	B	Blue	3	4
Reference signal	Z	Pink	2	6
Shield	Inner	–	1	–
	Outer	–	Case	Case

LM10IC – Digital output signals, RS422

Square wave differential line driver to RS422

Power supply *	4.7 V to 7 V – voltage on readhead Reverse polarity protection
Power consumption	< 35 mA
Voltage drop over cable	~ 13 mV/m – without load ~ 54 mV/m – with 120 Ω load
Power supply rise time	< 1 ms (for PRG option only)
Response time **	< 100 ms < 10 μs (special option 02)
Output signals	3 square-wave signals A, B, Z and their inverted signals A–, B–, Z–
Reference signal	1 or more square-wave pulse Z and its inverted pulse Z–
Signal level	Differential line driver to EIA standard RS422: $U_H \geq 2.5 \text{ V}$ at $-I_H = 20 \text{ mA}$ $U_L \leq 0.5 \text{ V}$ at $I_L = 20 \text{ mA}$

Permissible load	$Z_0 \geq 100 \Omega$ between associated outputs $I_L \leq 20 \text{ mA}$ max. load per output Capacitive load $\leq 1000 \text{ pF}$ Outputs are protected against short circuit to 0 V and to +5 V Only one output shorted at a time
Alarm	High impedance on output lines A, B, A–, B– Special option 02: Alarm is not signalled by high impedance state ** Special option 07: Alarm signal is output parallel as line driver signal
Switching time (10 to 90 %)	t_+ , $t_- < 30 \text{ ns}$ (with 1 m cable and recommended input circuit)
Cable length *	Max. 100 m

* Please consider voltage drop over cable.

** See description on page 10.

Recommended signal termination

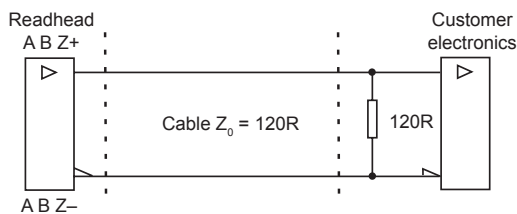

Timing diagram

Complementary signals not shown

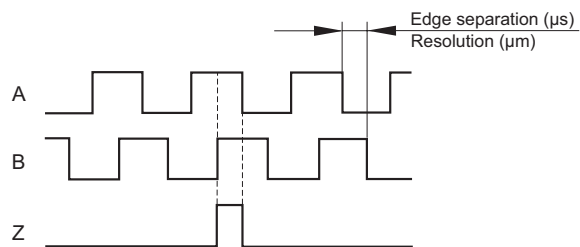

Connections

Function	Signal	Colour (option F)	15 pin D type plug (option D)	9 pin D type plug (option A)	15 pin HD type plug (option H)	7 pin DIN EN60130-9 plug (option U)
Power	5 V	Brown	7	5	7	5
	0 V	White	2	9	2	1
Incremental signals	A	Green	14	4	14	3
	A–	Yellow	6	8	6	–
	B	Blue	13	3	13	4
	B–	Red	5	7	5	–
Reference signals	Z	Pink	12	2	12	6
	Z–	Grey	4	6	4	–
Alarm	E	Violet	11	–	11	–
	E–	Black	3	–	3	–
Shield	Inner	–	15	1	15	–
	Outer	–	Case	Case	Case	Case

Programming (for IC output only)

Readheads can be ordered preset to the required resolution or provided so that they can be programmed as needed on the machine to the chosen resolution. This programming is carried out by connecting the readhead to a computer via a programming interface. The readhead must be ordered with the PRG resolution option to use this function. For more information on the programming function of LM10 readheads, please refer to the [UPRG01 programming interface datasheet](#).

Reference mark

Reference marks can be provided in 4 ways:

- 1) **Selected at point of order.** The LM10 readhead should be ordered with reference mark option A. Magnetic scale should be ordered with reference mark and in the case of magnetised reference an additional letter M should be added to the end of the scale ordering code. If required, the cover foil can be installed over reference marks.

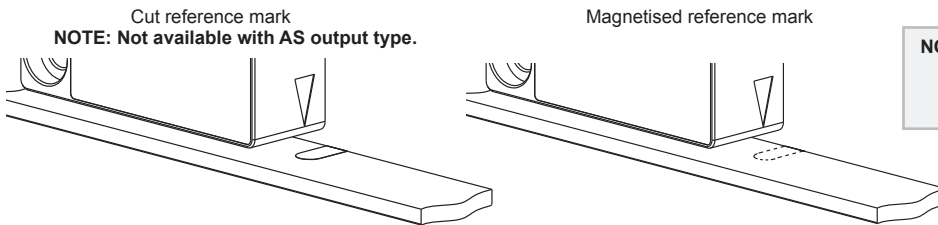

NOTE: The shape and position of the cut or magnetised reference are critical so these options are only available as factory order.

- 2) **Stick-on reference mark.** The LM10 readhead should be ordered with reference mark option A. Magnetic scale should be ordered with **no** reference mark. After installation of the scale a reference mark sticker can be applied to the scale at the required position using the reference mark applicator tool. Ensure that the reference sticker is oriented to the corresponding side of the readhead that has the reference mark designator marked.

NOTE: Not available with AS output type.

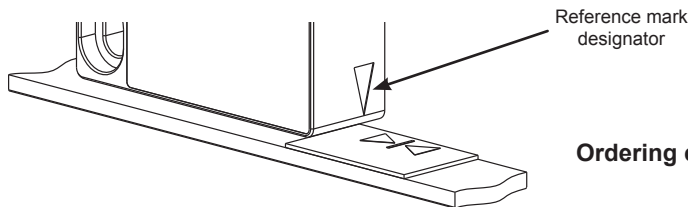

Ordering code: LM10SRM00

- 3) **Tool for custom selectable reference mark.** The LM10 readhead should be ordered with reference mark option A. Magnetic scale should be ordered with **no** reference mark. Operator can magnetise reference mark in a position to suit the application.



Ordering code: LM10CRM00

- 4) **Periodic reference impulse. Every 2 mm.** The LM10 readhead should be ordered with reference mark option C. Magnetic scale should be ordered with **no** reference mark. Position information is output in incremental quadrature format with periodic reference impulses. Reference periods correspond to pole length of magnetisation.

Distance coded reference marks. The LM10 readhead should be ordered with reference mark option A. The distance coded reference mark option provides multiple reference marks that are individually spaced according to specific mathematical algorithm. Absolute position is calculated after traversing 2 successive reference marks. Maximum length and minimal traverse depend on basic spacing (K) between reference marks, which is customer selectable at point of order. For further information please refer to [Distance coded reference mark data sheet \(LM10D17\)](#).

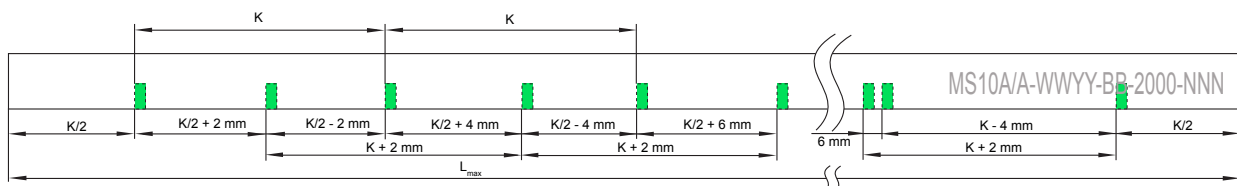

Multiple reference marks. For cut reference marks on multiple locations on the MS magnetic scale please [contact RLS](#) for a special part numbering.

A RENISHAW  associate company

Positive direction

Digital output signals – A leads B

Analogue output signals ($1 V_{pp}$) – V_1 leads V_2

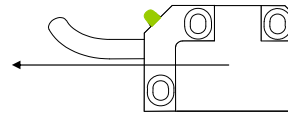

Status LED

After the installation of the magnetic scale (see LM10 Installation guide) the readhead can be easily adjusted on the machine using the set-up LED indicator. When special option 07 (additional alarm outputs) is selected status of LED is available also by additional lines (HI = green LED, LO = red LED).

LED	Status	Possible reason
Green	Good signal strength/set-up	-
Red	Poor signal strength - adjustment required A, B, A-, B- become high impedance	Incorrect readhead orientation. Readhead installation out of tolerance.
Red/green flashing	IB, IC_02, IA_02: poor signal strength	Demagnetisation of measuring scale. Insufficient power supply voltage.

Response time

	LM10AV/AS	LM10IB	LM10IC_02	LM10IA_02	LM10IC	LM10IA
Set-up time	10 ms					
Conversion time	<250 ns					
Transition time	<10 μ s			<100 ms		

Set-up time is the time needed for the encoder readhead to start reading the position information after power-on (see diagram 1).

Conversion time is the time needed for the encoder readhead to convert the position information into an output signal.

Transition time is the time it takes the encoder readhead to switch from an alarm state to a valid output signal (see diagram 2).

Diagram 1: Set-up time

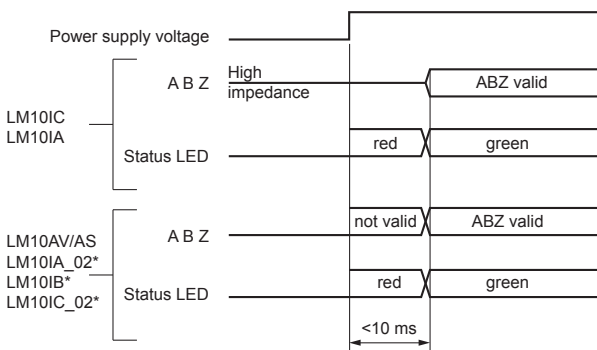

* In alarm state LED flashes red/green.

Diagram 2: Transition time

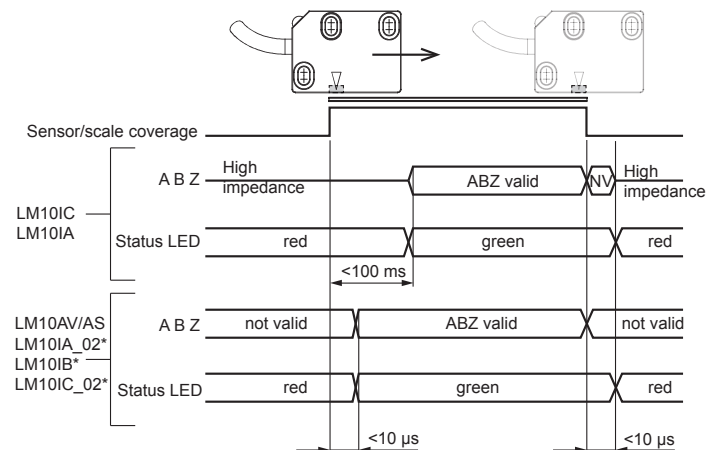

Readhead part numbering



LM10 IC 010 C A 10 F 00

Output type

AS - Analogue voltage $1V_{pp}$, wide reference pulse, 5 V
AV - Analogue voltage, $1V_{pp}$, 5 V
IA - Incremental Push-Pull outputs; 5 V – 30 V
IB - Incremental, Open Collector NPN; 5 V – 30 V
IC - Incremental, RS422; 5 V

Resolution/interpolation factor

For **AS** and **AV**: **000** - N/A
 For **IA**, **IB** and **IC**:

13B - 8192	09B - 512	020 - 100 (20 μ m)
12B - 4096	D50 - 500	D08 - 80
11B - 2048	005 - 400 (5 μ m)	06B - 64
001 - 2000 (1 μ m)	D32 - 320	050 - 40 (50 μ m)
1D6 - 1600	08B - 256	05B - 32
10B - 1024	010 - 200 (10 μ m)	04B - 16 (125 μ m)
002 - 1000 (2 μ m)	D16 - 160	03B - 8 (250 μ m)
D80 - 800	07B - 128	

PRG - Programmable, preset to 1 μ m (for **IC** only)

For resolutions in μ m see table on page 4.

Minimum edge separation

For **AS** and **AV**: **A** - N/A
 For **IA**, **IB** and **IC**:

K - 0.07 μ s (15 MHz)¹
A - 0.12 μ s (8 MHz)²
B - 0.5 μ s (2 MHz)
C - 1 μ s (1 MHz)
D - 2 μ s (0.5 MHz)
E - 4 μ s (0.25 MHz)
F - 5 μ s (0.2 MHz)
G - 10 μ s (0.1 MHz)
H - 20 μ s (0.05 MHz)

Special requirements

00 - No special requirements (standard)
02 - Shortened reaction time (for **IA**, **IC**; not available for **PRG** option)
07 - Additional alarm output (for **IA**, **IC**; not available for **PRG** option)
10 - Not potted, protected to IP50
19 - Stainless steel housing
40 - Protective stainless-steel tube for cable
0M - Cable length in meters

Connector option

A - 9 pin D type plug⁵
D - 15 pin D type plug (for **IA** and **IC**)
F - Flying lead (no connector)³
H - 15 pin HD type plug (for **IA** and **IC**)
L - 15 pin D type plug (for **AV** and **AS**)
P - 9 pin D type plug (for **AV** and **AS**)
U - 7 pin DIN EN60130-9 plug (for **IA** and **IC**)⁵

Cable length

10 - 1.0 m (standard)
 (eg. 13 - 1.3 m cable and
 13 - 13 m cable if special option **0M** is chosen)

Reference

A - With reference sensor¹
B - No reference sensor⁴
C - Periodic reference impulse as per scale pitch (every 2 mm)⁴

¹ Not available with 03B and 04B interpolation factors.
² Default for **PRG** option; not available with 03B interpolation factor.
³ The **PRG** option comes with a plastic connector.
⁴ Not available with **AS** output type.
⁵ Not available with special option 07.

Magnetic scale part numbering

Dimensions in mm.

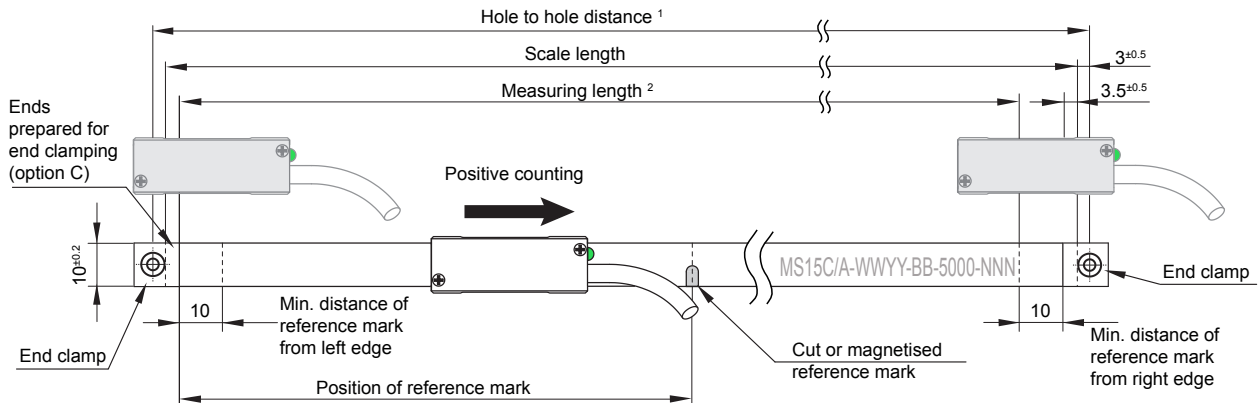

- ¹ Hole to hole distance = scale length + 6⁺¹ mm (for end clamp mounting)
² Measuring length = scale length - 20 mm

MS10 B 1000 B 0032

Accuracy grade

- A - ±20 µm
- B - ±40 µm

Scale length

- xxxx - Where xxxx equals scale length in cm
- Mxxx - Where xxx equals scale length in mm (for scale lengths below 1 m)

Options

- A - VHB back-adhesive tape (standard)
- B - VHB back-adhesive tape, with cover foil*
- C - VHB back-adhesive tape, ends prepared for end clamping
- G - No VHB back-adhesive tape, sides prepared for insertion into track section²
- H - No VHB back-adhesive tape, sides prepared for insertion into track section, with cover foil²
- I - No back-adhesive tape
- N - No back-adhesive tape, with cover foil*
- P - No back-adhesive tape, ends prepared for end clamping

Reference mark

- 0000 - No reference mark
- xxxx - Cut reference mark; Where xxxx equals position of machined reference mark in cm (reference mark position will be within ±0.5 mm from requested position)**
- Mxxx - Cut reference mark; Where xxx equals position of machined reference mark in mm (for scale lengths below 1 m)**
- Dxxx - Distance coded reference mark; where xxx equals basic increment in mm¹
- xxxxM - Magnetised reference mark; where xxxx equals position of magnetised reference mark in cm (reference mark position will be within ±0.5 mm from requested position)
- MxxxM - Magnetised reference mark in mm; where xxx equals position of magnetised reference mark in mm (reference mark position will be within ±0.5 mm from requested position)

* Cover foil supplied separately.

** Not available for AS output type.

Cover foil part numbering

Cover foil CF10 1000

Width of cover foil

- CF08 - Width 8 mm (for TRS option only)²
- CF10 - Width 10 mm

Foil length

- xxxx - Where xxxx equals foil length in cm

¹ For details on DCRM system please refer to data sheet LM10D17 on www.rls.si/lm10.

² For details on TRS system please refer to data sheet LM10D18 on www.rls.si/trs.

Accessories part numbering



Stick-on reference mark
LM10SRM00

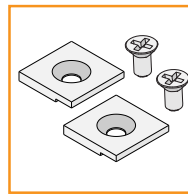

End clamp kit
(2 clamps + 2 screws)
LM10ECL00



Applicator tool for stick-on
reference mark
LM10ARM00

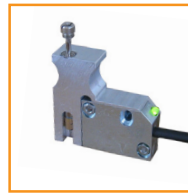

Tool for custom selectable
reference mark
LM10CRM00



Applicator tool for magnetic
scale and cover foil
LM10ASC00



Programmable interface
UPRG01



USB encoder interface
E201



Magnet viewer
MM0001

Accessories for MS Track System



Track section, 1.00 M
TRS100A00



Track section, 2.00 M
TRS200A00



Scale clamp
TRE004A00



Joining element
TRE004A01



Screw and washer
TRC00

Head office

RLS merilna tehnika d.o.o.

Poslovna cona Žeje pri Komendi
Pod vrbami 2
SI-1218 Komenda
Slovenia

T +386 1 5272100

F +386 1 5272129

E mail@rls.si

www.rls.si

Document issues

Issue	Date	Page	Corrections made
12	24. 9. 2014	2	Magnetic scale thickness (D) updated
		3	Storage and handling added
		4	Maximum speed table updated
		5, 6	Output types IA and AS and connections tables added
		9	Magnetisation tool option added
		10	Response time information added
		11	Part numbering for IA and AS outputs added
		12	Magnetic scale options updated and scale length diagram updated
		13	Accessories list updated
13	1. 2. 2016	2	AS output type installation tolerance added
		6, 7	IA and IB are without reverse polarity protection
		7	Maximum cable length updated with additional edge separation values
		11	AS output type availability updated
		12	Scale length/measuring length updated, VHB options D, E and F removed, magnetised reference mark option added
14	19. 12. 2016	1	RoHS compliant added
		3	Magnetic scale thickness table and notes amended
		4	Cable specifications amended
		5	Notes for AS output type amended
		6, 8	Alarm added
		7	Connection U added
		5-8	Connections descriptions amended
		11-13	Part numbering amended

RLS merilna tehnika d.o.o. has made considerable effort to ensure the content of this document is correct at the date of publication but makes no warranties or representations regarding the content. RLS merilna tehnika d.o.o. excludes liability, howsoever arising, for any inaccuracies in this document.
© 2016 RLS d.o.o.