

MILLTRONICS

XRS-5/XRS-5C TRANSDUCER

Instruction Manual PL-590

January 2001

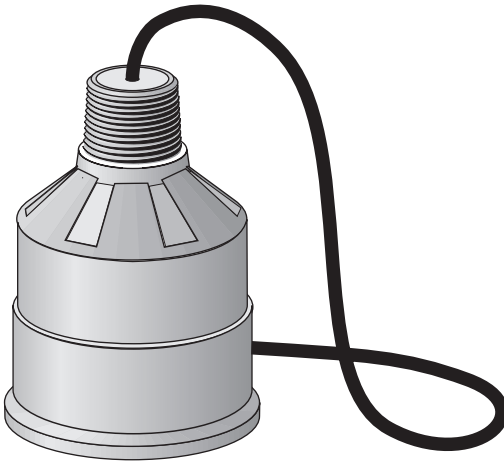

Safety Guidelines

Warning notices must be observed to ensure personal safety as well as that of others, and to protect the product and the connected equipment. These warning notices are accompanied by a clarification of the level of caution to be observed.

Qualified Personnel

This device/system may only be set up and operated in conjunction with this manual. Qualified personnel are only authorized to install and operate this equipment in accordance with established safety practices and standards.

Warning: This product can only function properly and safely if it is correctly transported, stored, installed, set up, operated, and maintained.

Note: Always use product in accordance with specifications.

Copyright Siemens Milltronics Process Instruments Inc. 2000. All Rights Reserved

Disclaimer of Liability

This document is available in bound version and in electronic version. We encourage users to purchase authorized bound manuals, or to view electronic versions as designed and authored by Siemens Milltronics Process Instruments Inc. Siemens Milltronics Process Instruments Inc. will not be responsible for the contents of partial or whole reproductions of either bound or electronic versions.

While we have verified the contents of this manual for agreement with the instrumentation described, variations remain possible. Thus we cannot guarantee full agreement. The contents of this manual are regularly reviewed and corrections are included in subsequent editions. We welcome all suggestions for improvement.

Technical data subject to change.

MILLTRONICS® is a registered trademark of Siemens Milltronics Process Instruments Inc.

Contact SMPI Technical Publications at the following address:

Technical Publications
Siemens Milltronics Process Instruments Inc.
1954 Technology Drive, P.O. Box 4225
Peterborough, Ontario, Canada, K9J 7B1
Email: techpubs@milltronics.com

For the library of SMPI instruction manuals, visit our Web site: www.milltronics.com

Table of Contents

| | |
|---|-----------|
| Table of Contents | 3 |
| Specifications | 5 |
| About the Transducer..... | 7 |
| General Guidelines | 8 |
| Installation | 9 |
| Outline and Dimensions | 9 |
| Mounting..... | 11 |
| Recommendations | 11 |
| Applications..... | 13 |
| Open Channel Meter..... | 13 |
| Standpipes and Stilling Wells..... | 14 |
| Water / Wastewater..... | 15 |
| Transducer Placement | 16 |
| Locations..... | 16 |
| Interconnection | 19 |
| Direct Connection | 19 |
| Coaxial Connection | 20 |
| 2-Wire Extension (for EnviroRanger ERS 500 only)..... | 20 |
| Maintenance | 20 |
| Installation Diagram for XRS-5..... | 21 |
| Installation Diagram for XRS-5C..... | 22 |

Specifications

Process Application:

- liquids and slurries
- Measurement Range
- Vessel Pressure
- 0.3 to 8m (1 - 26 ft) typical (application variables apply)
- vented to atmosphere

Operation:

- Beam Angle
- Frequency
- Temperature Sensor
- Supply Source
- 10°
- 43 KHz
- internal
- transducer shall only be supplied by Milltronics certified controller

Environmental:

- Location
- Ambient temperatures
- Altitude
- Pollution degree
- indoor / outdoor
- -20 to 65 °C (-4 to 149 °F)
- 2000 m maximum
- 4

Construction:

- Housing
- Mounting
- Kynar Flex^{®1} body and Hypalon^{®2} face
- XRS-5C has SS conduit connection
- XRS-5: 1" NPT or BSP conduit connection
- XRS-5C: 1" NPT

Cable:

- 2 wire shielded / twisted, 0.5 mm² (18 AWG) PVC jacket

Ingress protection:

- IP-68

Weight³:

- 1.2 Kg (2.6 lb)

Options:

- factory flanged to suit ANSI , DIN or JIS standard
- split flange (field mount) to suit ANSI, DIN or JIS standard
- submergence shield (flooding applications)

Cabling (maximum run):

- 365 m (1200 ft) using RG-62 A/U coaxial cable
- 365 m (1200 ft) using 2-wire twisted pair / braided and foil shielded 20 AWG (0.5 mm²), PVC jacket (EnviroRanger ERS 500 only)

Approvals:

- XRS-5: CE⁴, CSA, FM, CENELEC/ATEX, SAA, see device nameplate
- XRS-5C: CSA
- Please verify against the device nameplate

¹ Kynar Flex[®] is registered trademark of ELF Atochem.

² Hypalon[®] is a registered trademark of Du Pont

³ approximate weight of transducer with standard cable length

⁴ EMC performance available upon request

About the Transducer

The Echomax XRS-5 transducer works with Milltronics transceivers and provides the ultrasonic pulse and echo reception that these devices require.

The transducer converts electrical pulses provided by the transceiver to ultrasonic pulses used for measurement and then converts the ultrasonic echoes back to an electrical signal. This signal is interpreted by the Milltronics transceiver using the patented Sonic Intelligence™ algorithms. The ultrasonic pulse reduces in power by 3dB in a 10° cone from the transducer face. It is important to keep objects out of this cone to reduce the chance of false echos being recorded.

The XRS-5 transducer incorporates an integral temperature sensor that reports the ambient temperature to the transceiver. The connection is transparent in that both the ultrasonic and temperature components of the transducer use the same leads. This ensures that the Milltronics transceiver can automatically compensate the speed of sound constant for varying temperatures.

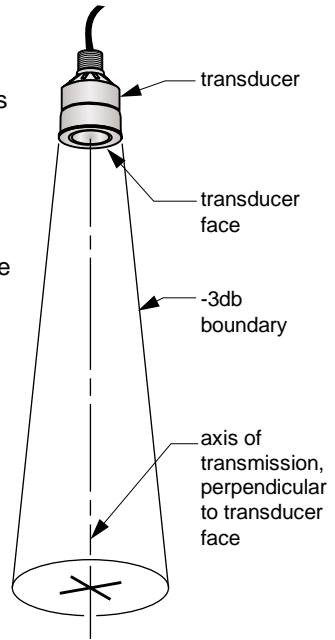

General Guidelines

The equipment may be used in all hazardous zones with all gases with temperature classes T1, T2, T3, T4, T5 and T6. The equipment is only certified for use in ambient temperatures in the range of -20°C to +65°C and should not be used outside this range.

- Installation shall be carried out in accordance with the applicable code of practice by suitably trained personnel.
- The apparatus shall only be supplied from a circuit containing a suitably-rated fuse having a breaking capacity of 4000A. This fuse is included in Milltronics' transceivers.
- Repair of this equipment shall be carried out in accordance with the applicable code of practice.
- The certification of this equipment relies on the following materials used in its construction:

Enclosure: Kynar Flex 2800-02 (former designation 2820) / Chlorosulfonated polyethylene / Nitrile / Ethylene propylene / Chloroprene

Encapsulant: LA-9823-76

- Manual override can be accomplished by using the disconnect switch provided in the building installation of the associated controller.

Installation

Outline and Dimensions

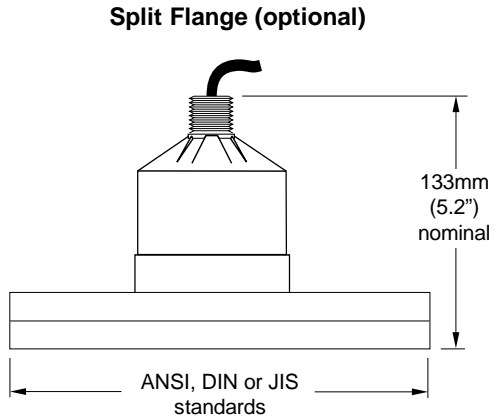
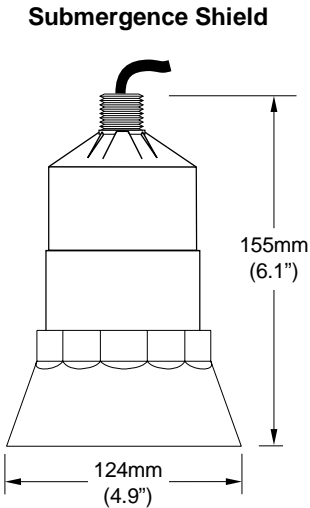
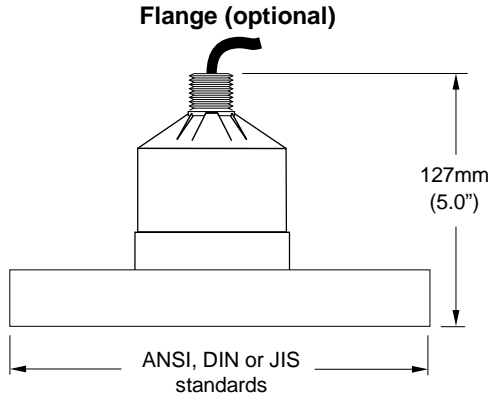
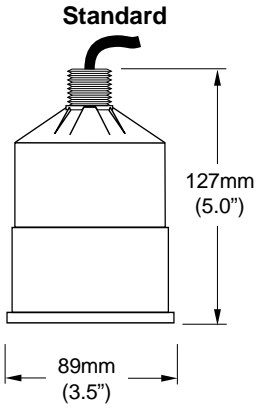

Refer to Milltronics
instruction manual PL-530.

Mounting

Recommendations

- Mount the transducer so that it is *above the maximum material level by more than the blanking value* to ensure that accurate results are achieved. Refer to the associated transceiver manual for information on setting the blanking value.
- The transducer must be mounted so that the axis of transmission is *perpendicular to the liquid's surface*.
- *Do not over tighten mounting.* Hand tightening of the mounting hardware is sufficient.
- Consider the optional *temperature sensor* when mounting the transducer.

Suspended Conduit

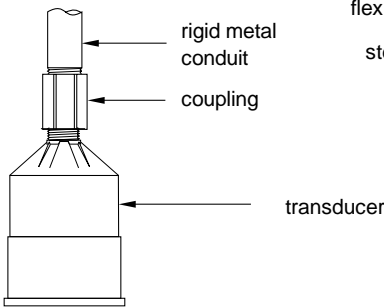

Bracket

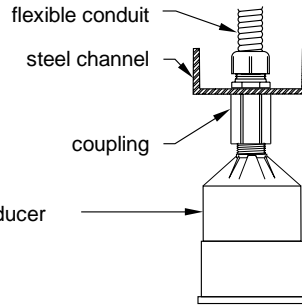

Flexible conduit transducer should not be subjected to wind, vibration or jarring.

Submersible

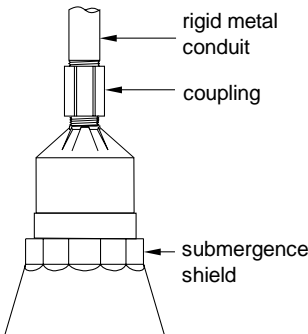

Submersible transducer, used in applications where flooding is possible.

Plywood

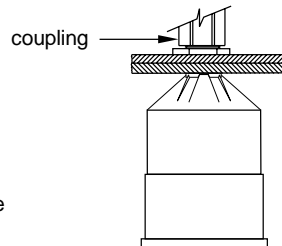

Plywood mounting provides excellent isolation, but must be rigid enough to avoid flexing if subjected to loading.

Blind Flange

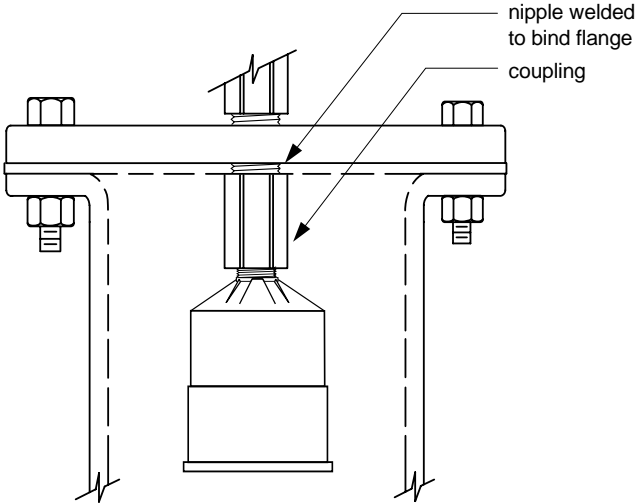

Face Flange

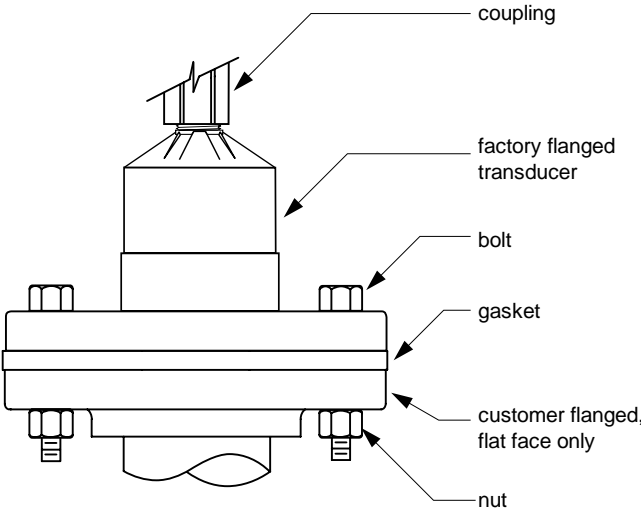

Note:

Tighten the flange bolts evenly in order to ensure a good seal between the mating flanges.

Caution: Over tightening can cause performance degradation.

Mounting

Applications

Notes:

- The transducer is to be used only in the manner outlined in this instruction manual.
- This transducer requires no maintenance, and is recommended for use with liquids only.
- The OCM III requires the use of the TS-2 external temperature sensor. The internal temperature sensor in the XRS-5 cannot be used.

Open Channel Meter

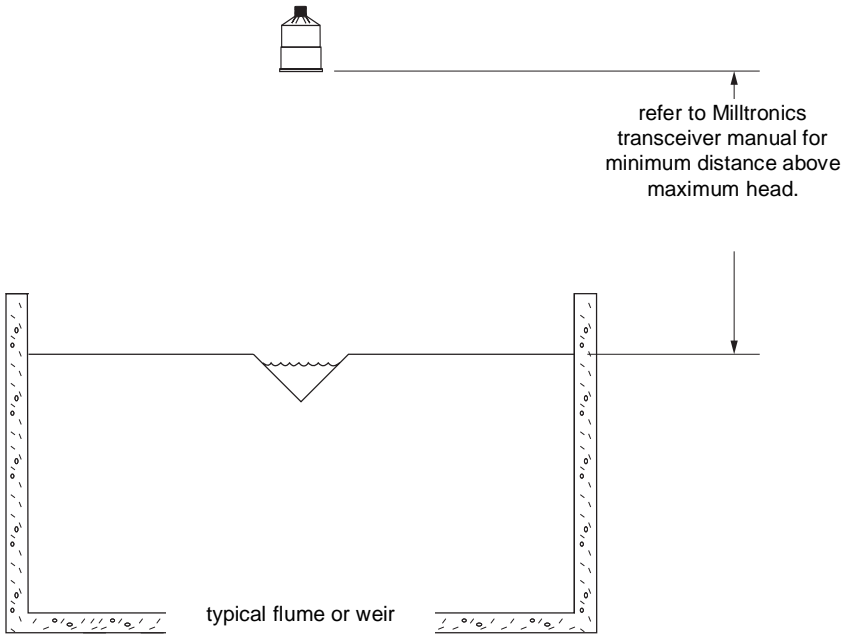

Refer to OCM manufacturer specification for proper point of head measurement.

The OCM III requires the use of the TS-2 external temperature sensor instead of the XRS-5 internal temperature sensor. The use of an external temperature sensor provides better temperature tracking in applications where the temperature can change quickly.

Standpipes and Stilling Wells

In many applications, access must be made via a standpipe. In such cases, Milltronics can provide factory flanged transducers or split flange kit that will readily mate to the flanged standpipe. Another option is to hang the transducer from a blind flange.

The standpipe length should be as short and the diameter as large as possible. As a rule of thumb, the -3 dB cone of the sound beam should not intersect the standpipe wall in applications opening into a vessel or larger area. Otherwise, additional blanking will be required to compensate for the interference zone created by the opening.

Note: When using a stilling well, make sure there is no build-up, welds, couplings, or other debris on the inside of the well wall. This can affect reliability of level measurement.

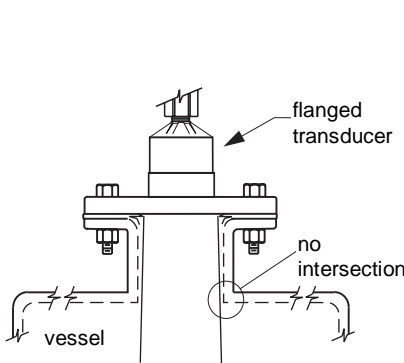

no additional blanking required

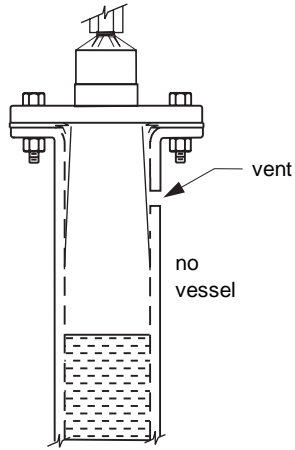

no additional blanking required

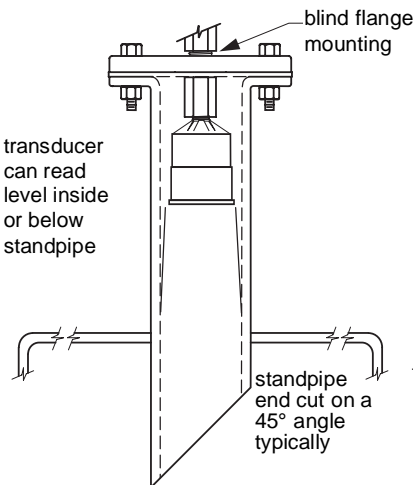

no additional blanking required

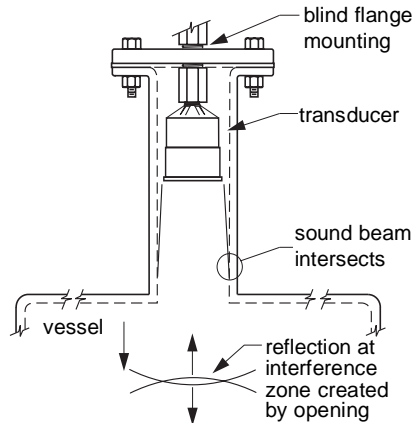

near blanking extension of 150 mm (6") past end of standpipe may be required.

Water / Wastewater

Differential Level

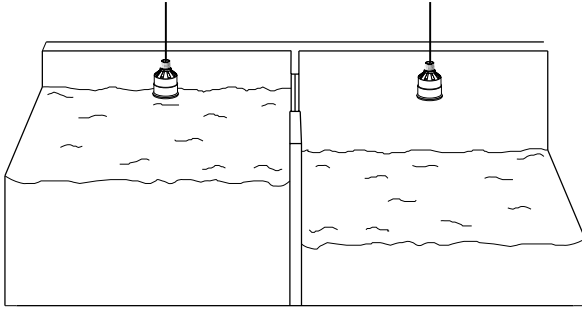

Pump Control

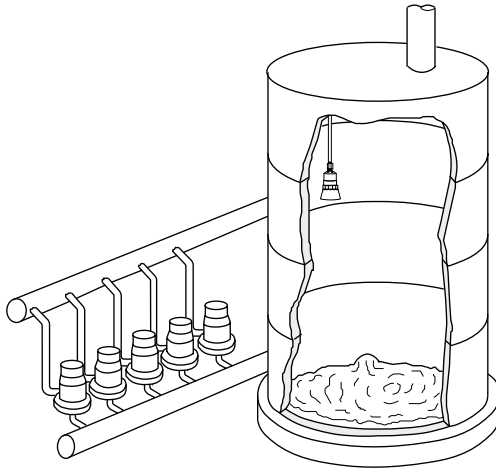

Sewage Lift

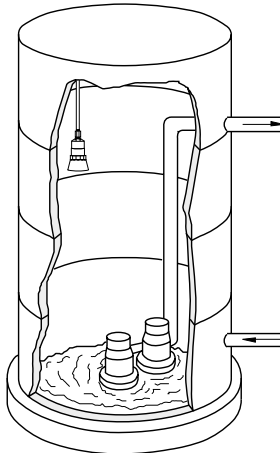

Transducer Placement

The following graphic shows the best placement of the XRS-5 transducer.

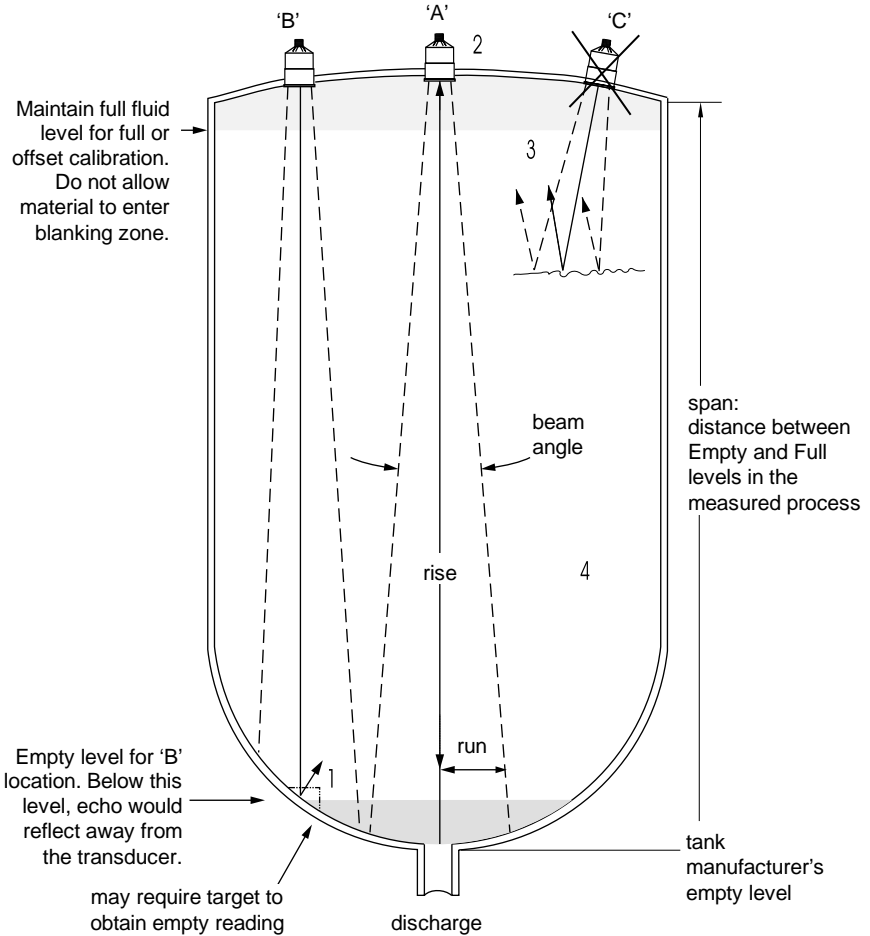

Locations

- A. **Primary location.** This is the preferred location and should be used whenever possible. The centre of the tank generally gives the most reliable readings because there are fewer obstructions to provide false echos.
- B. **Alternate location.** This location is used if the centre of the tank is already in use or if the tank roof is too weak to hold the transducer safely.
- C. **Poor location.** This is a poor installation location. The echos are shown reflecting away from the transducer face.

Notes

1. **Beam should not detect bin bottom.**

If this occurs, use range extension parameters (on transceivers where available) to omit false echoes. The XRS-5 transducer operates with a beam angle of 10° and has a rise:run ratio of approximately 12:1. This means that for every 1m (3.3') of tank height, the transducer projects a circular area over the material surface with a radius of 83mm (32.7"). In most tanks the transducer should be centred as much as possible (without interference from inlet) for optimum reading range.

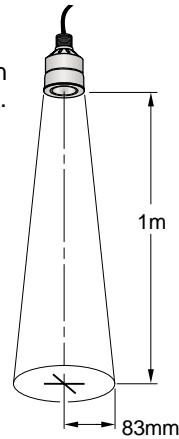

2. **Sound beam must be perpendicular to liquid surface.**

When mounting the standpipe and flange you must ensure that the transducer face will be parallel with the liquid's surface.

3. **Echo has missed an improperly levelled transducer.**

As 2, ensure that the standpipe and flange are mounted to set the transducer face level with the measured liquid.

4. **Calibrate under normal conditions.**

When performing an empty or full calibration, the tank must contain its normal vapour and be at its normal temperature.

Interconnection

Note:

Installation shall only be performed by qualified personnel and in accordance with local governing regulations.

Dos and Don'ts

For best results follow these installation rules:

- Do not route cable openly, instead run cable separately in a grounded metal conduit to protect it from ambient electrical noise.
- Seal all thread connections to prevent the ingress of moisture.
- Do not run cable near high voltage or current runs, contactors or SCR control drives.

In all of the following examples the terminal blocks on the transceiver are described in the transceiver manual.

Direct Connection

Connect the transducer directly to the Milltronics transceiver via the 2 conductor shielded cable.

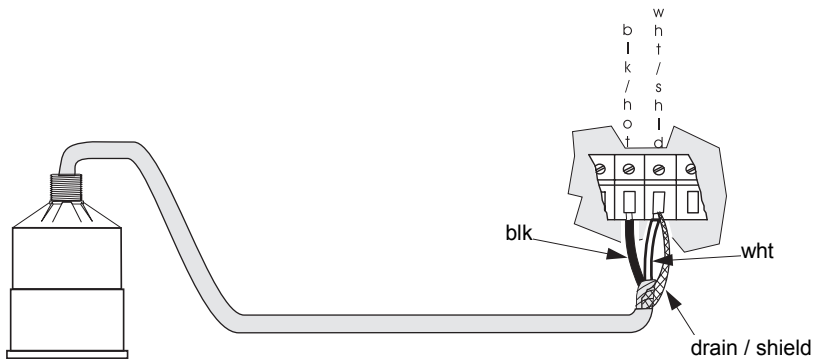

Note:

When connecting to an EnviroRanger ERS 500, the white, black, and shield wires are all connected separately. Do not tie the white and shield wires together.

Coaxial Connection

Connect the transducer to the Milltronics transceiver via a junction box and RG-62 A/U coaxial cable. This setup is effective for combined runs up to 365m (1200').

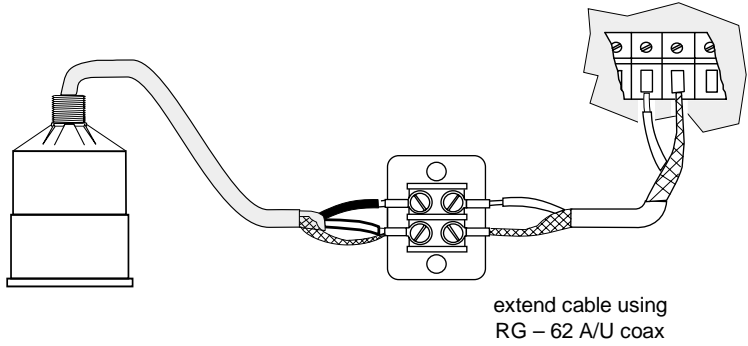

Note:
When connecting to an EnviroRanger ERS 500, do NOT use coaxial cable, see diagram below for proper procedure.

2-Wire Extension (for EnviroRanger ERS 500 only)

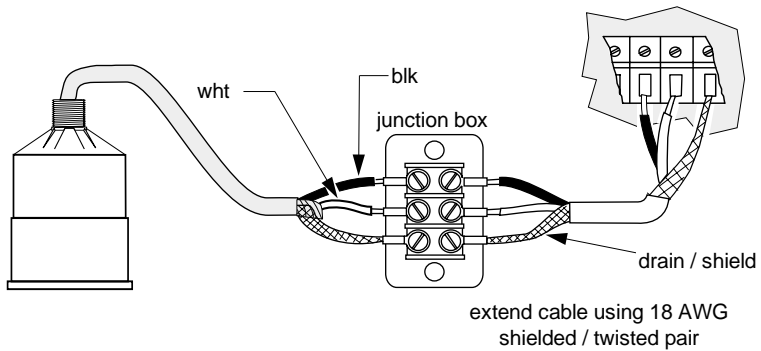

Maintenance

Normally, no maintenance is required on the transducer.

However, if performance changes are observed, immediately shut down the level measurement system and perform a thorough inspection, especially on the transducer.

Installation Diagram for XRS-5

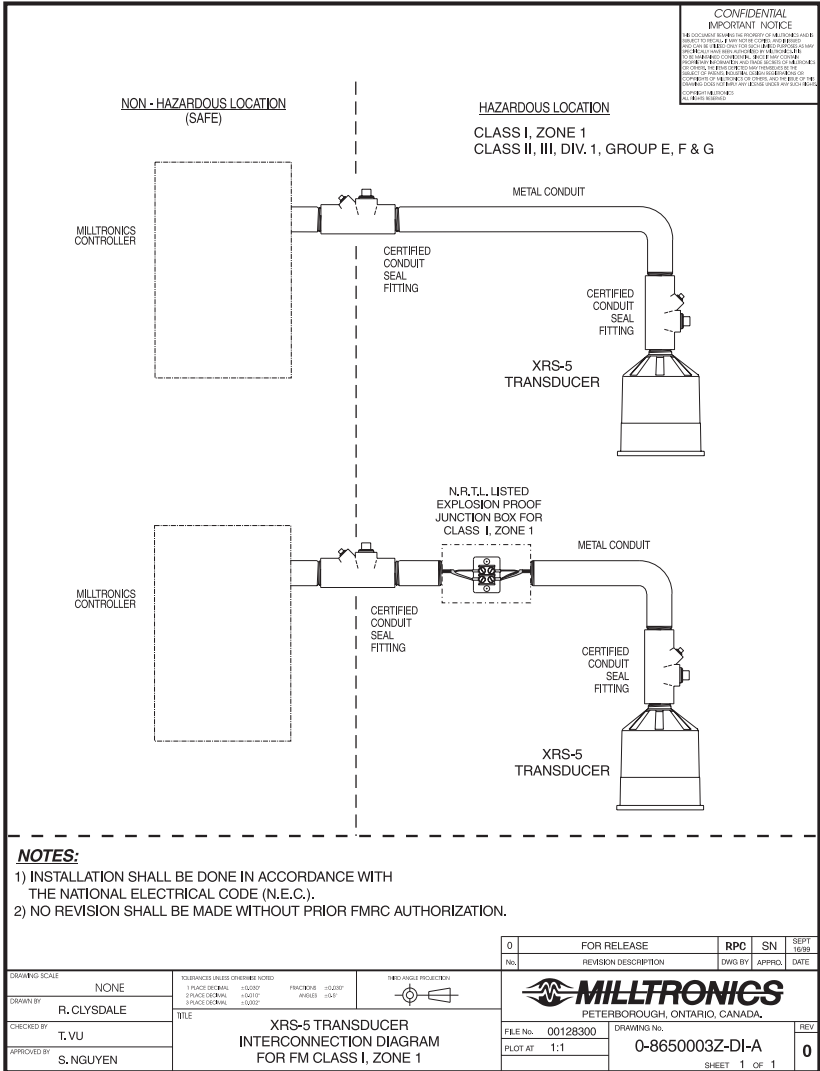

Installation Diagram

Installation Diagram for XRS-5C

Installation Diagram

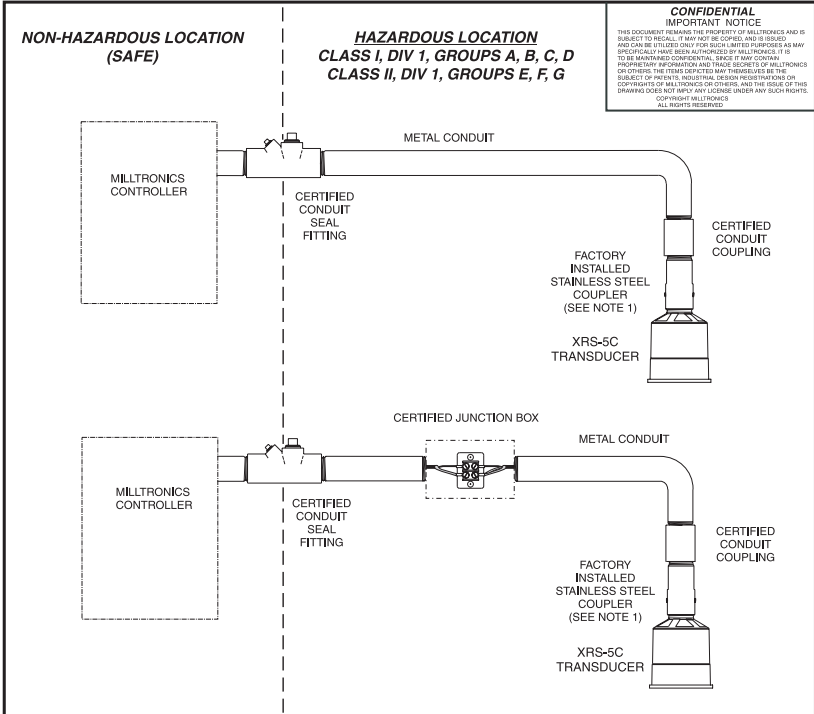

CONFIDENTIAL
IMPORTANT NOTICE
 THIS DOCUMENT REMAINS THE PROPERTY OF MILLTRONICS AND IS SUBJECT TO REGULATION. IT MAY NOT BE COPIED AND IS ISSUED AND CAN BE UTILIZED ONLY FOR SUCH LIMITED PURPOSES AS MAY BE SPECIFICALLY AND EXPLICITLY AUTHORIZED BY MILLTRONICS. IT IS THE PROPRIETARY INFORMATION AND TRADE SECRETS OF MILLTRONICS AND SHOULD BE KEPT CONFIDENTIAL. SUCH INFORMATION IS THE SUBJECT OF PATENT, INDUSTRIAL DESIGN PROTECTIONS OR COPYRIGHTS OF MILLTRONICS OR OTHERS, AND THE REUSE OF THIS DRAWING DOES NOT IMPLY ANY LICENSE UNDER ANY SUCH RIGHTS. COPYRIGHT MILLTRONICS ALL RIGHTS RESERVED.

NOTES:

1. FOR CONDUIT MOUNTING: APPLY TIGHTENING TORQUE TO THE STAINLESS STEEL COUPLER ONLY, AND NOT TO THE TRANSDUCER HOUSING, OTHERWISE IT MAY IMPAIR SUITABILITY FOR USE IN HAZARDOUS LOCATIONS.
2. DO NOT SECURE TRANSDUCER HOUSING TO STRUCTURAL SUPPORTS WITH METAL CLAMPING DEVICES.
3. INSTALLATION SHALL BE DONE IN ACCORDANCE WITH CANADIAN ELECTRICAL CODE PART 1 REQUIREMENTS.
4. ASSURE ELECTRICAL CONTINUITY AT COUPLING / CONDUIT THREADED JOINT.

| | | | | | | | | | |
|--------------------------|--|---|--|------------------------|------------------|-----------|----|-------------------------|--------------------|
| | | USE DIMENSIONS ONLY - DO NOT SCALE | | 0 | FOR CONSTRUCTION | RPC | SN | SEPT 2000 | |
| DRAWING SCALE NONE | | TOLERANCES UNLESS OTHERWISE NOTED 1 PLACE DECIMAL = 0.005" FINISH TO 0.005" 2 PLACE DECIMAL = 0.001" FINISH TO 0.001" 3 PLACE DECIMAL = 0.0005" FINISH TO 0.0005" | | THIRD ANGLE PROJECTION | | No. | | REVISION DESCRIPTION | DWS BY APPRO. DATE |
| DRAWN BY R. CLYSDALE | | TITLE XRS-5C TRANSDUCER INTERCONNECTION DIAGRAM FOR HAZARDOUS LOCATIONS | | FILE No. 2365016200 | | SIZE A | | DRAWING No. 23650162 | |
| CHECKED BY R. HARE | | | | PLOT AT 1=1 | | | | REV. 0 | |
| APPROVED BY S. NGUYEN | | | | JOB No. | | | | SHEET 1 OF 1 | |



www.milltronics.com

MILLTRONICS

Siemens Milltronics Process Instruments Inc.
1954 Technology Drive, P.O. Box 4225
Peterborough, ON, Canada K9J 7B1
Tel: (705) 745-2431 Fax: (705) 741-0466
www.milltronics.com

© Siemens Milltronics Process Instruments Inc. 2000
Subject to change without prior notice



7 M L 1 9 9 8 1 B J 0 1
Printed in Canada